



1-800-248-7717 • 1002 N. 15th Street, Middlesboro, KY 40965

TELESCOPING FLIP TARP

INSTALLATION INSTRUCTIONS



TELESCOPING FLIP TARP INSTALLATION

Congratulations on your purchase of a Mountain Tarp *Telescoping Flip Tarp* tarping system for Dump Body trailers. With tarping systems for Dump Bodies, Transfer Trailers, Scrap Trailers, Landscaping trucks and Roll-Offs, Mountain Tarp offers the most complete line of tarping systems and parts in the industry.

Note:

Please read through instructions for entire system and follow instructions thoroughly to ensure your system will work properly. It is important that you inspect your trailer and prepare it for installation by removing any sharp edges or anything that will cause damage to your tarp.

For further technical assistance, contact our corporate headquarters at (800) 248-7717 or email us at sales@mountaintarp.com. For parts and service, visit us at one of our locations in Kentucky, Texas, or Ohio, or contact one of our many dealers nationwide. To learn more about Mountain Tarp and products we offer, visit us online at www.mountaintarp.com.

WARNING:

- Never operate system under power lines, this may cause injury due to electrocution.
- Never operate tarp system while moving.

TOOLS REQUIRED:

Ratchet
 5/16", 3/8", 1/2", 9/16" and 3/4" Sockets and Wrenches
 Allen Wrench Set
 Welder - Steel and Aluminum (Optional)

Screw Driver
 Drill
 3/8" and 1/2" Drill Bits
 Snap Clamps

CONTENTS OF TELESCOPING FLIP TARP SYSTEM			
DESCRIPTION	QTY	DESCRIPTION	QTY
3pc TARP AXLE ASSY	1	CROSSOVER FOR TELESCOPING KIT	1
3pc FACE SHIELD & END PLATES	1	SUPER TORQUE MOTOR w/ GEARBOX	1
TELESCOPING ARM ASSY (PS)	1	ELEC. KIT BAG	1
TELESCOPING ARM ASSY (DS)	1	ARM BOLT BAG	1

TABLE OF CONTENTS

Step 1: Head Roller Assembly	2	Maintenance	5
Step 2: Clock Spring Underbody Assembly	3	Wiring Diagrams	6-8
Step 3: Arms	4	Parts Guide	9
Step 4: Tarp	5		
Step 5: Crossover	5		

TELESCOPING FLIP TARP INSTALLATION

STEP 1: INSTALLING HEAD ROLLER ASSEMBLY

Mounting the roller assembly on top of the cab protector, see figure 1.

1A:

The first step is to choose the proper location on the cab protector to install the Face Shield & End Plate assembly. (Note: The assembly should be located at the position on the cab protector so that when the system is in the uncovered position the tarp arms do not interfere with either the doors or the loading process). Extend the Face Shield to fit over the width of your cab protector. When the proper location is achieved the next step is to mount the end plates.

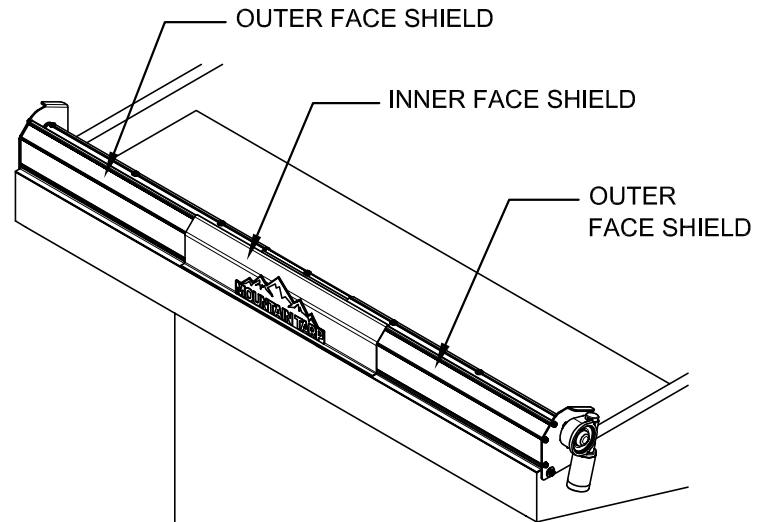

figure 1

1B:

With the center of the end plate at the previously determined position, hold the end plate so that the bottom flange of the Outer Face Shield is flush with the top of the rail on the cab protector, see figure 1a. Then, using a 1/2" drill bit, drill two holes near the bottom of the end plate, through the end plate and the rail. Then using 1/2" x 1-1/2" hex bolts, 1/2" flat washers and 1/2" locknuts, mount the end plate firmly to the cab protector. Repeat this on the other side of the body.

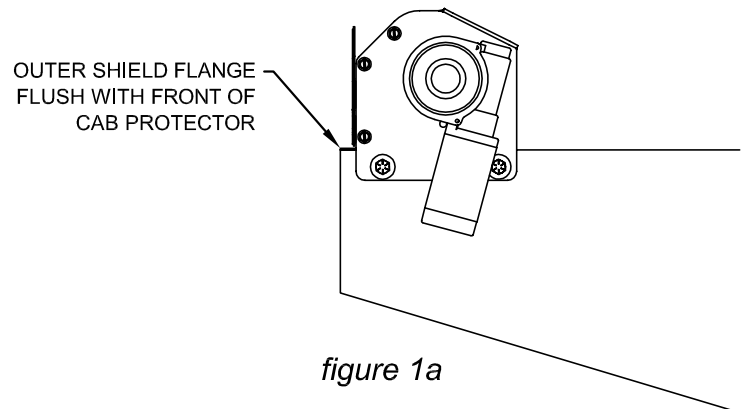

figure 1a

1C:

With the end plates secured, slide the inner face shield into the center position. Then, using 1/4"-14 x 1" self-tapping screws, fasten the inner shield in place on each bottom corner of the lower flange.

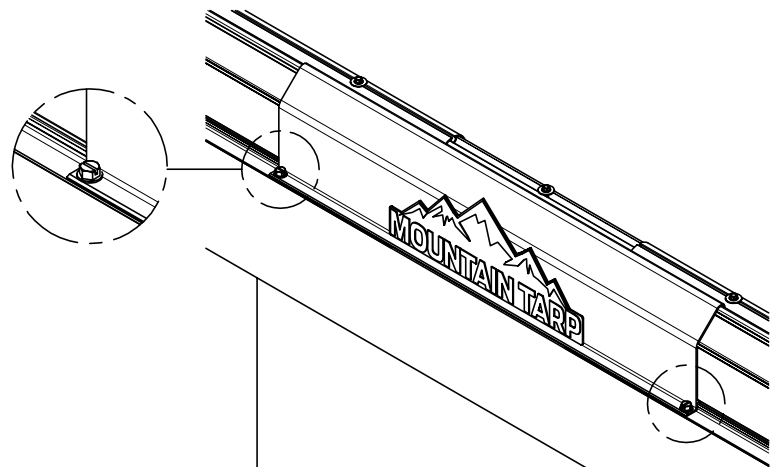

figure 1b

TELESCOPING FLIP TARP INSTALLATION

STEP 2: INSTALLING UNDERBODY ASSEMBLY

2A:

Finding the placement for the underbody assembly (pivot point). See *Figure 3*. To find the placement for the underbody assembly you must find the center point of the dump body. Using two tape measures, hook the end of one to the tarp axle and the end of the other to the very top rear corner of the tailgate and measure toward the center at the bottom of the body. At the distance where the tape measures cross reading the same measurement is the center point of the system.

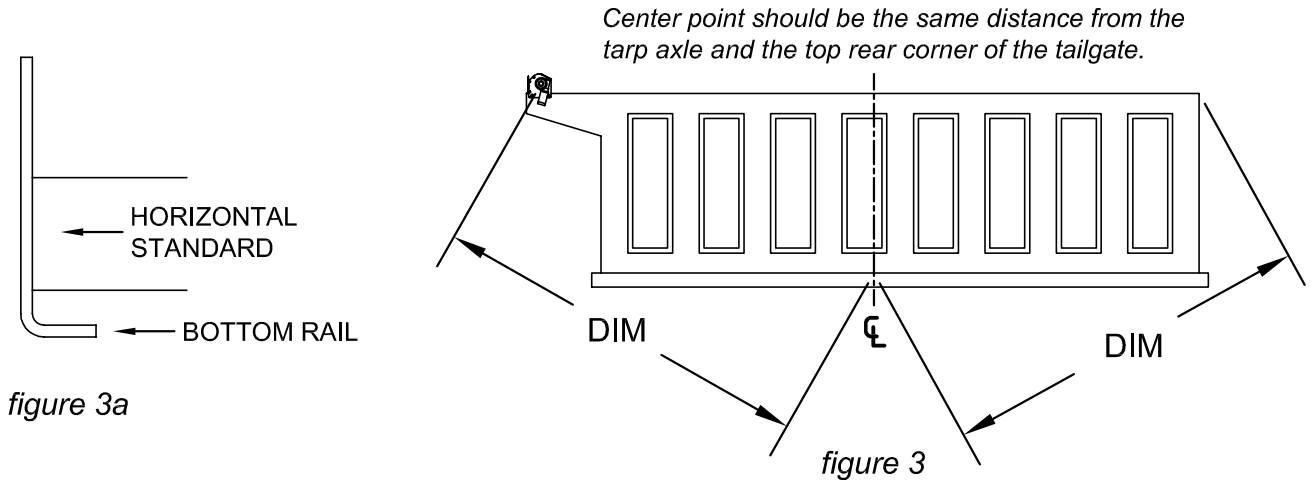

STEP 3: INSTALLING CLOCK SPRING UNDERBODY ASSEMBLY

3A:

Installing the Clock Spring Assembly, See *Step 2* for establishing pivot point. After marking the pivot point, place the pivot pin as shown in *figure 3c* and mark holes to be drilled. Once holes have been marked, drill 1/2" holes and bolt pivot to body using the supplied bolts (or weld), ensuring that the spring notch is pointed down.

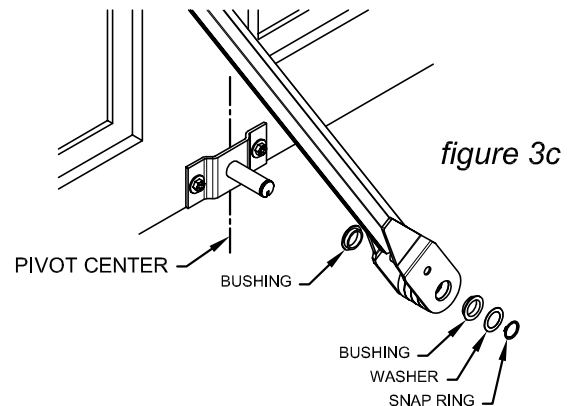

3B:

Install the spring assembly connector as shown. See *figure 3c* (Note: Pivots are directional, rotate pivots so that the spring hooks will clip over the inside pin as shown in *figure 3d*).

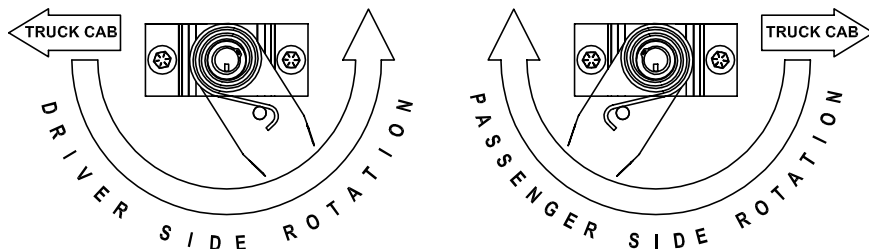

figure 3d

TELESCOPING FLIP TARP INSTALLATION

STEP 4: CONNECTING THE ARMS

4A:

Connecting the Arms to the Spring Shaft. Before connecting the arms you must first determine the length they need to be. This will allow for the legs on the crossover and the arm connector. (Note: this method of measurement is used if the pivot point of the system is at or less than seven inches from the center of the dump body. If this measurement is greater than seven inches then measure from the center of the spring shaft to the center of the tarp axle on the roller assembly and subtract 4". This will cause the system to fall just short of the rear of the tailgate), see *figure 4*.

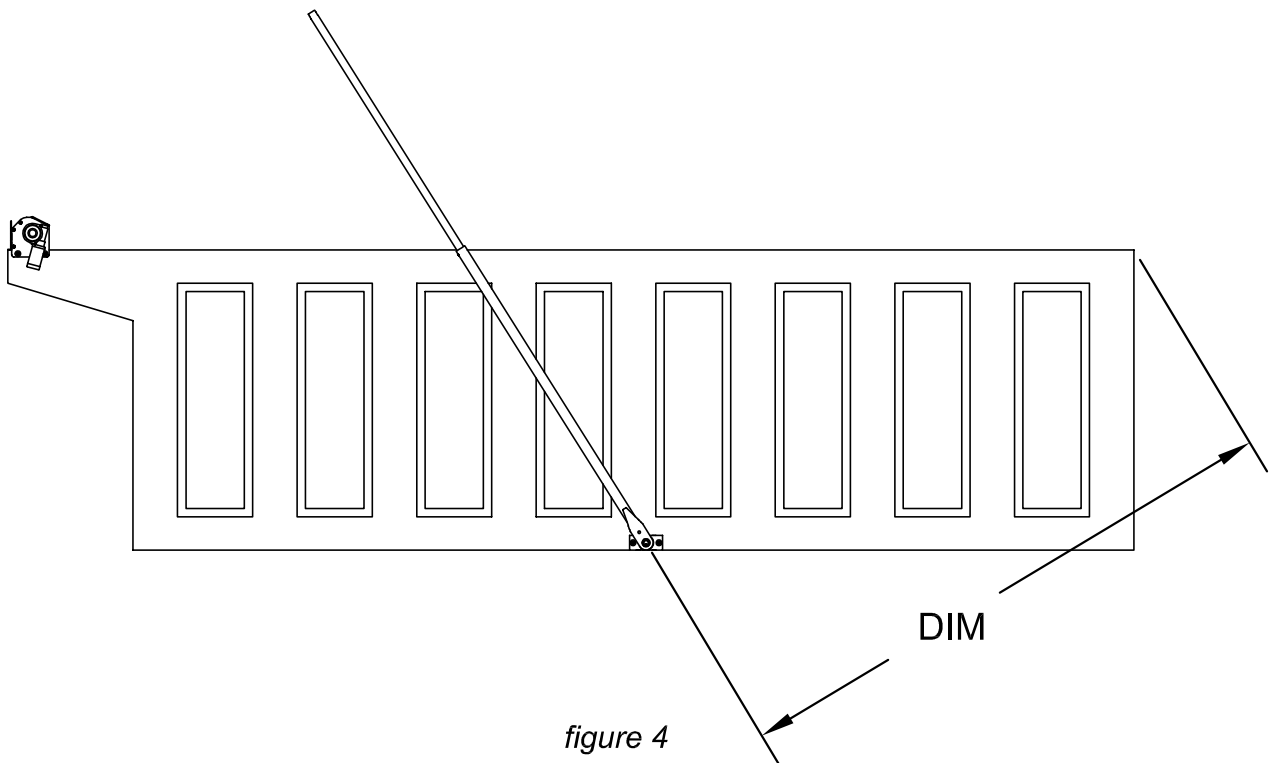

Once the required arm length is determined, the next step is to insert the upper arm into the lower arm. Slide the arm to length, but **do not** tighten set screws until after installing the crossover in *Step 6*.

*Note: Certain Dump Body types may require the upper arm be cut down if trailer is shorter than typical Body lengths.

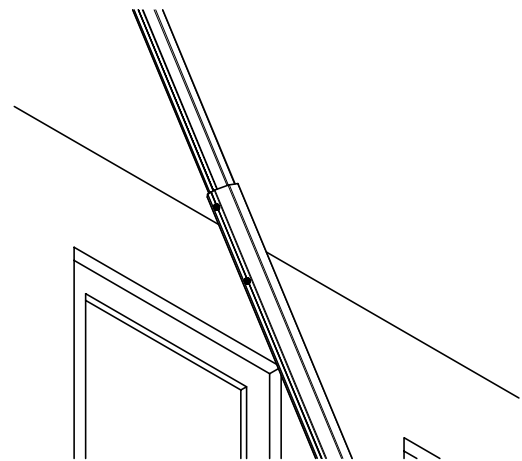

TELESCOPING FLIP TARP INSTALLATION

STEP 5: INSTALLING THE TARP

5A:
Connecting the tarp to the tarp axle, see *figure 5*. Attach the tarp to the 3pc Telescoping Axle with 1/4"-14 x 1" self-tapping screws and 1/4" washers as shown in *figure 5*.

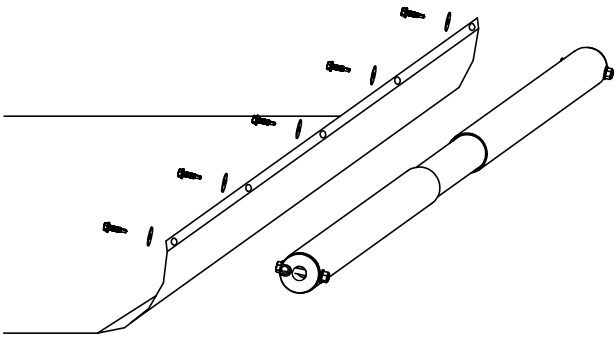

figure 5

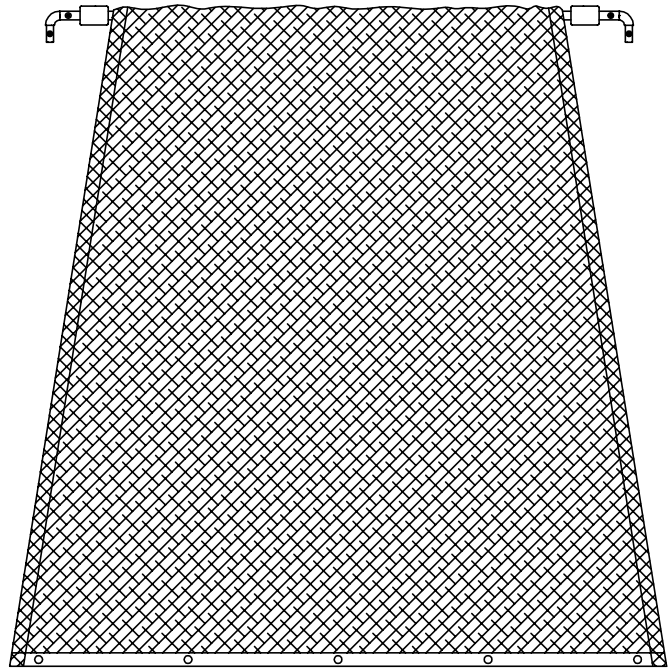

figure 5a

STEP 6: INSTALLING THE CROSSOVER

6A:
Installing the crossover onto the arms. Using a ladder, lift the arms up to the top of the tailgate. With the tarp attached, slide the legs of the crossover into the end of the upper arm on each side of the trailer. Using 3/8" x 2-1/2" hex bolts, 3/8" flat washers, and 3/8" locknuts, secure the crossover elbow to the arm. Repeat steps for the opposite side of the trailer.

6B:
Securing arms in place. Slide the arms to length, and tighten both set screws on each side to secure the arms in place.

MAINTENANCE

- Brush springs with steel brush weekly to remove dirt, and spray with penetrating oil.



MOTOR WIRING DIAGRAM FOR ROCKER SWITCH

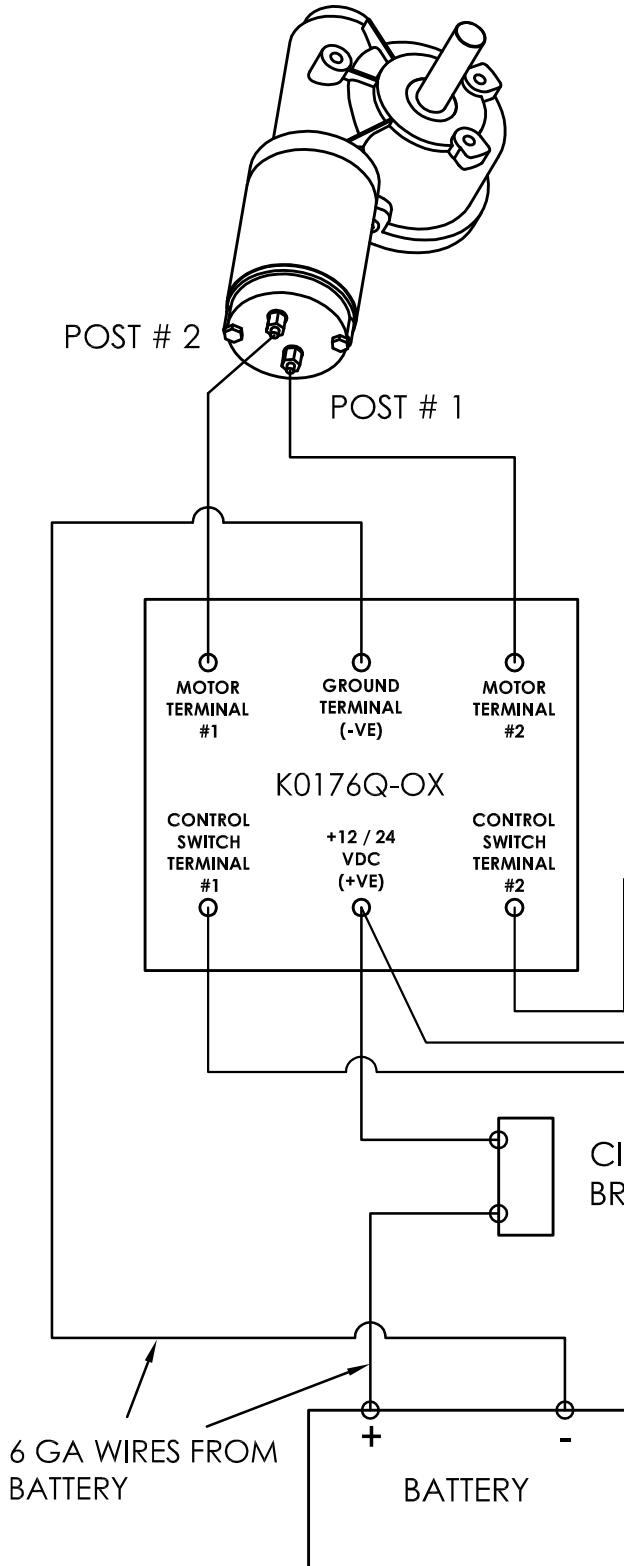

- CONNECT **MOTOR TERMINAL 1** STUD TO **MOTOR POST # 2**
- CONNECT **MOTOR TERMINAL 2** STUD TO **MOTOR POST # 1**
- CONNECT **GROUND TERMINAL (-VE)** TO NEGATIVE BATTERY TERMINAL
- CONNECT **+12 / 24 VDC (+VE) TERMINAL** TO APPROPRIATE IN-LINE CIRCUIT BREAKER

- CONNECT **OUTPUT 1** OF CONTROL SWITCH TO **CONTROL SWITCH TERMINAL #2**
- CONNECT **OUTPUT 2** OF CONTROL SWITCH TO **+12 / 24 VDC (+VE) TERMINAL**
- CONNECT **OUTPUT 3** OF CONTROL SWITCH TO **CONTROL SWITCH TERMINAL #1**

CONTROL SWITCH MUST BE A SPOT SWITCH. TO PROTECT YOUR MOTOR, DON'T USE THIS DEVICE WITHOUT A CIRCUIT BREAKER IN-LINE WITH +12 / 24 VDC

IMPORTANT: WIRE EXACTLY PER THE DIAGRAM. DO NOT WIRE ANY ACCESSORIES TO THE ROCKER SWITCH.

WIRES BETWEEN THE BATTERY AND MOTOR ARE TO BE 6 GAUGE. WIRES GOING TO THE SWITCH ARE TO BE 14 GAUGE.



WIRING DIAGRAM FOR WIRELESS REMOTE UNIT

- CONNECT MOTOR TERMINAL 1 STUD TO MOTOR POST # 2
- CONNECT MOTOR TERMINAL 2 STUD TO MOTOR POST # 1
- CONNECT GROUND TERMINAL (-VE) TO NEGATIVE BATTERY TERMINAL
- CONNECT +12 / 24 VDC (+VE) TERMINAL TO APPROPRIATE IN-LINE CIRCUIT BREAKER

- CONNECT OUTPUT 1 OF CONTROL SWITCH TO CONTROL SWITCH TERMINAL #2
- CONNECT OUTPUT 2 OF CONTROL SWITCH TO +12 / 24 VDC (+VE) TERMINAL
- CONNECT OUTPUT 3 OF CONTROL SWITCH TO CONTROL SWITCH TERMINAL #1

CONTROL SWITCH MUST BE A SPOT SWITCH. TO PROTECT YOUR MOTOR, DONT USE THIS DEVICE WITHOUT A CIRCUIT BREAKER IN-LINE WITH +12 / 24 VDC

WIRELESS UNIT

- CONNECT YELLOW WIRE TO GROUND TERMINAL (-VE)
- CONNECT RED WIRE TO +12 / 24 VDC (+VE) TERMINAL
- CONNECT BLACK WIRE TO CONTROL SWITCH OUTPUT 3
- CONNECT WHITE WIRE TO CONTROL SWITCH OUTPUT 1

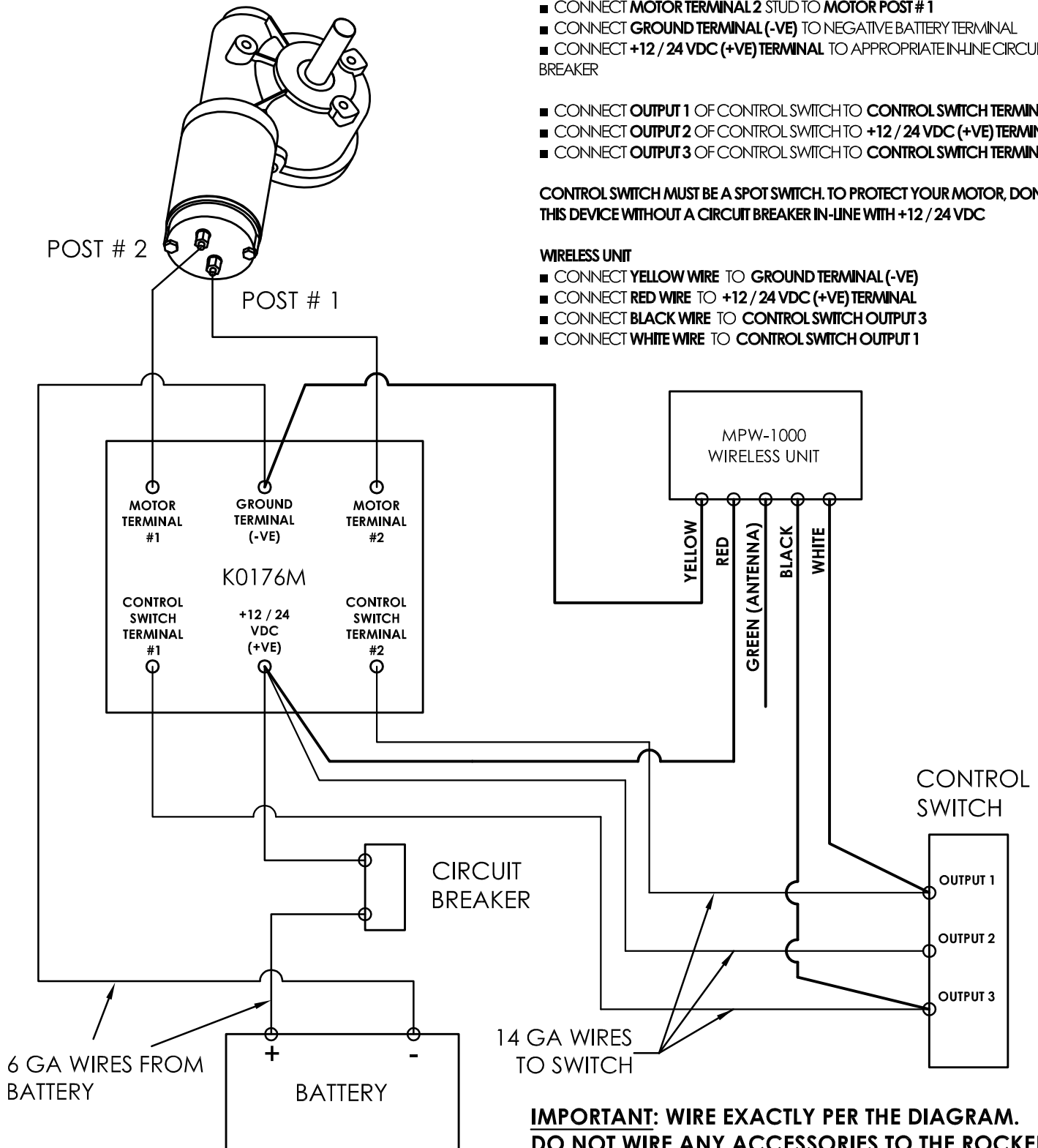

IMPORTANT: WIRE EXACTLY PER THE DIAGRAM. DO NOT WIRE ANY ACCESSORIES TO THE ROCKER SWITCH.



WIRING DIAGRAM FOR ROTARY SWITCH

- CONNECT SWITCH CONNECTION A1 TO MOTOR POST # 2
- CONNECT SWITCH CONNECTION A2 TO MOTOR POST # 1

- CONNECT SWITCH CONNECTION B1 TO 40A IN-LINE CIRCUIT BREAKER
- CONNECT SWITCH CONNECTION B2 TO NEGATIVE BATTERY TERMINAL

RING TERMINALS

MOTOR: 1/4" RING TERMINAL

BATTERY: 3/8" RING TERMINAL

SWITCH: #10 RING TERMINAL

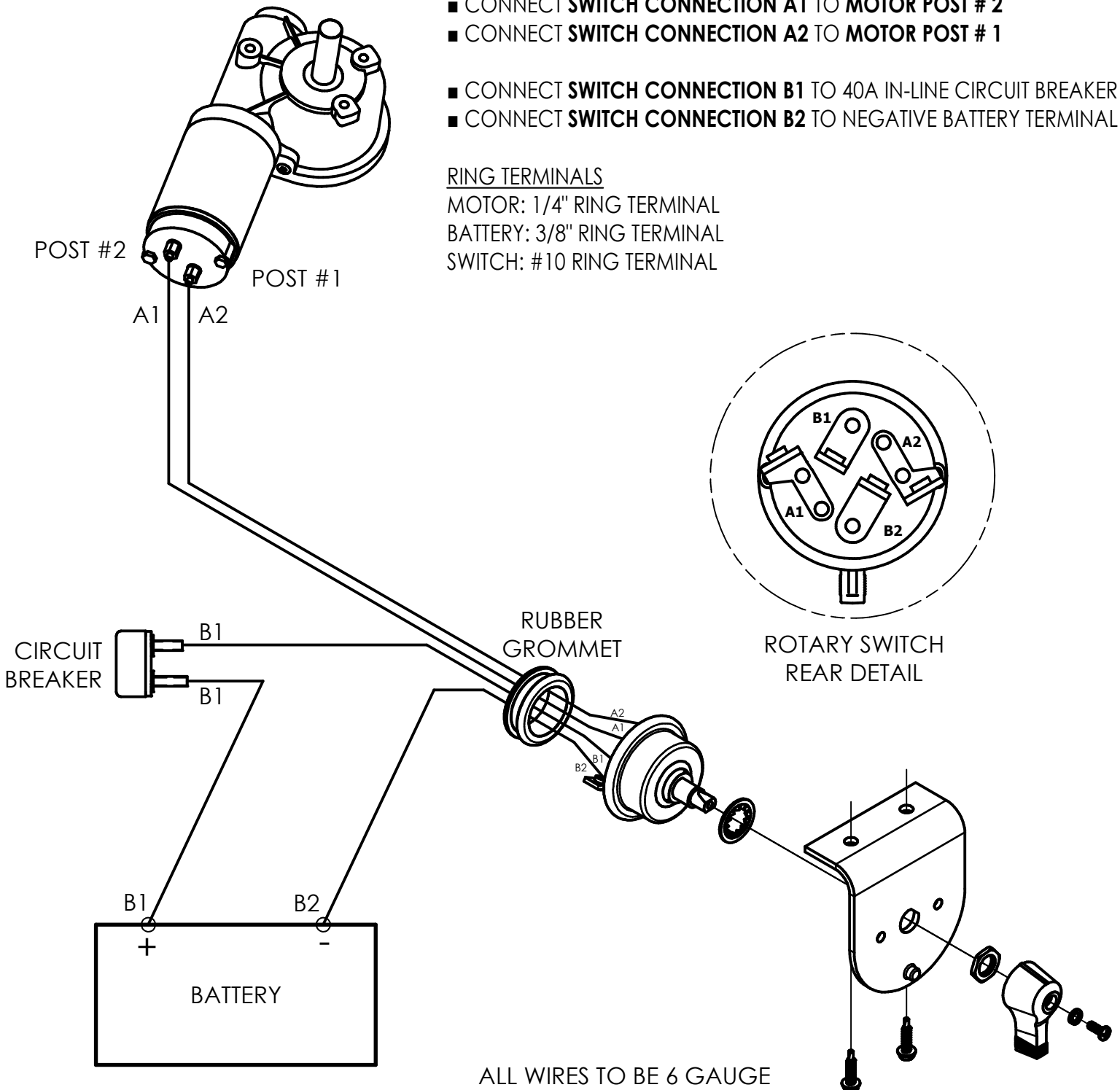

ALL WIRES TO BE 6 GAUGE

**IMPORTANT: WIRE EXACTLY PER DIAGRAM.
DO NOT WIRE ANY ACCESSORIES TO ROTARY SWITCH.**

TELESCOPING FLIP TARP ASSEMBLY

TELESCOPING ROLLER BOX K0100E

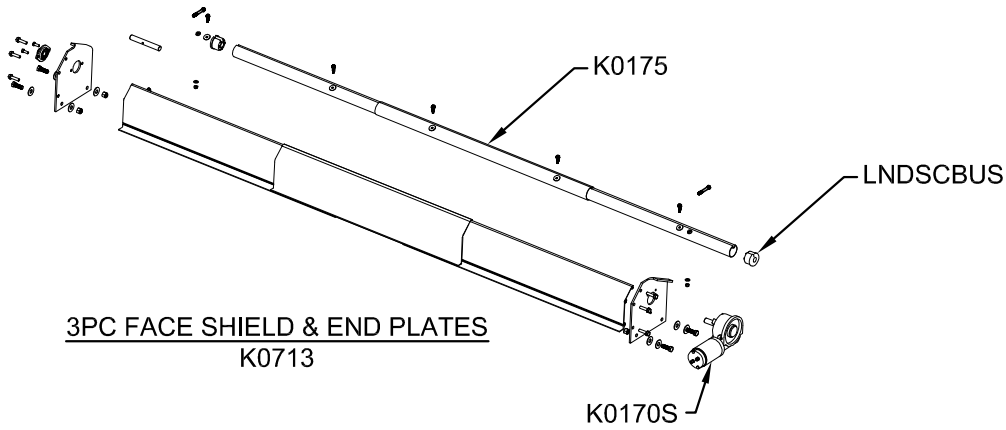

CROSSOVER FOR TELESCOPING KIT K0844

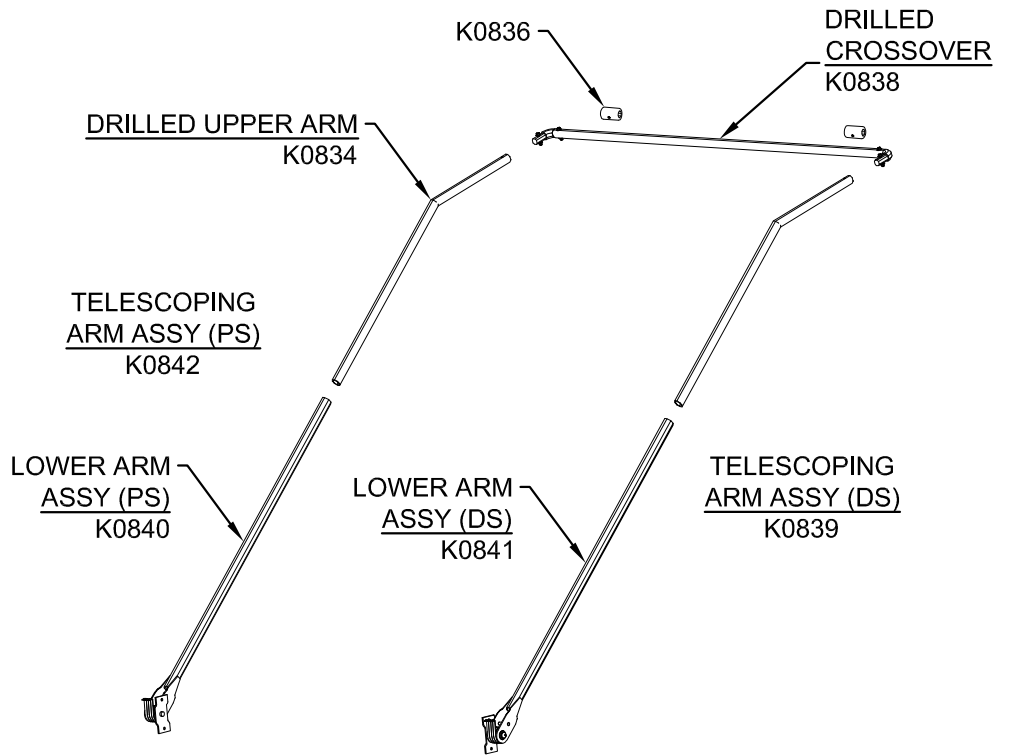

TELESCOPING ARM KIT w/ SPRINGS K0845C

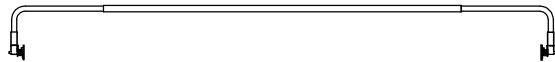

TENSION HOOP OPTION G1665A