

FLIP TARP ASSEMBLY FOR GANTRY SYSTEMS

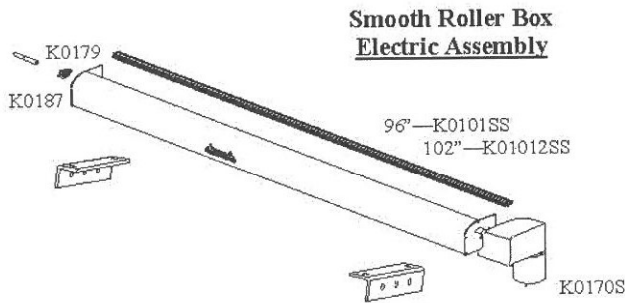

Arm Length:
16' w/ 6' Bend — K0411B6
16' Straight — K0411

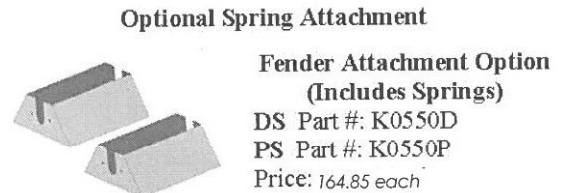
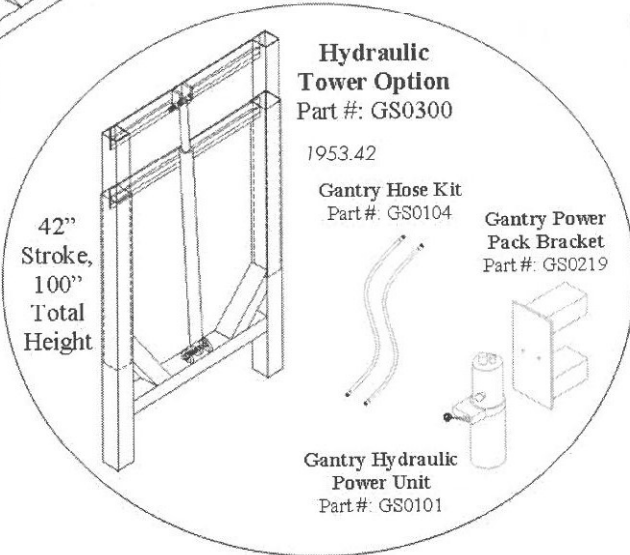
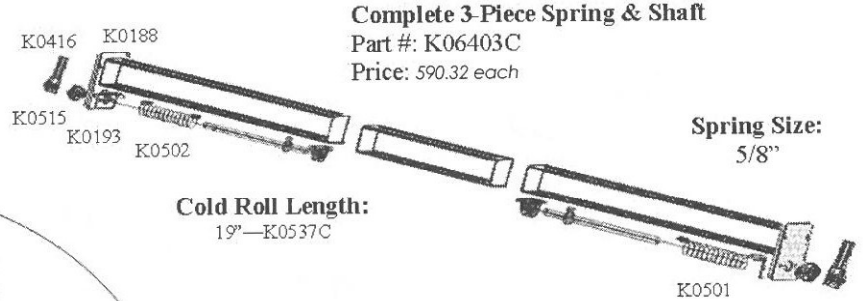
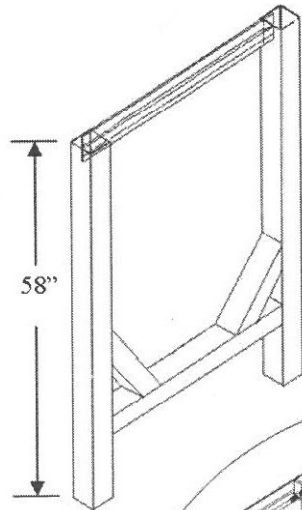
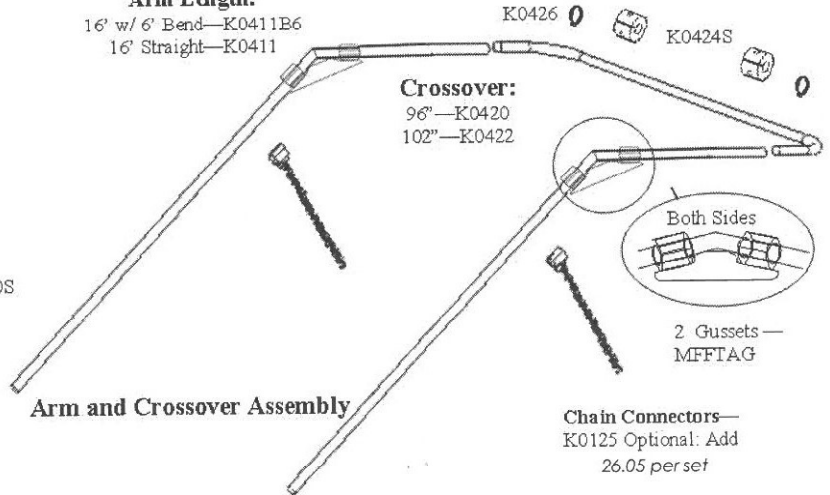

GUARANTEED UNBREAKABLE TARP ARM KITS

Note: Order Tarp So That Length Of Tarp Exceeds Length Of Trailer By One Foot.

* Tarp Sold Separately.

Part #	Kit Description	Price	Part #	Kit Description	Price
K616SSEG	96" Gantry with 16' Arms Electric	2235.77	K016SSEG	102" Gantry with 16' Arms Electric	2256.38

OPTIONS (Add to Above Kits):

Fender Attachment Option (Includes Springs)
Hydraulic Gantry Option

Part #: K0550D (DS) K0550P (PS)
Part #: GS0300

Deduct: 164.85 per set
Add: 1953.42